

Case History #1: ISPAT Inland, Inc.

East Chicago, IN

UNDESIRABLE EVENT: Catastrophic Failure of #4 BOF (Basic Oxygen Furnace)
Lance Carriage Assembly in the Steel Making Area.

UNDESIRABLE EVENT SUMMARY: During a routine slag wash, the operator in the pulpit (control room) was raising the 11-ton lance carriage. While raising the lance to its idle position approximately 80' above the fourth floor, a coupling on the drive platform failed, sending the lance carriage into a free fall. The carriage broke through the stop bolts and crashed into the 4th floor.

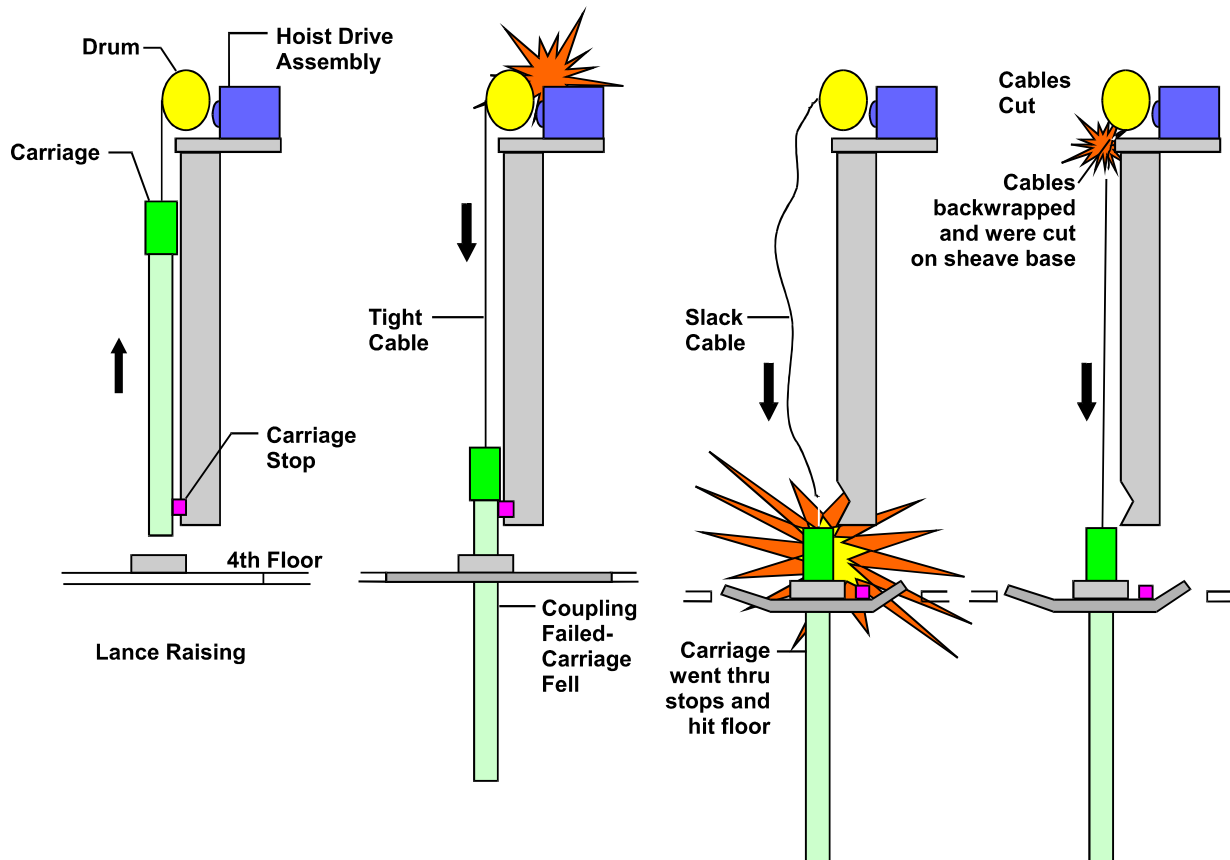

Figure 11.1: Lance Carriage Free Fall

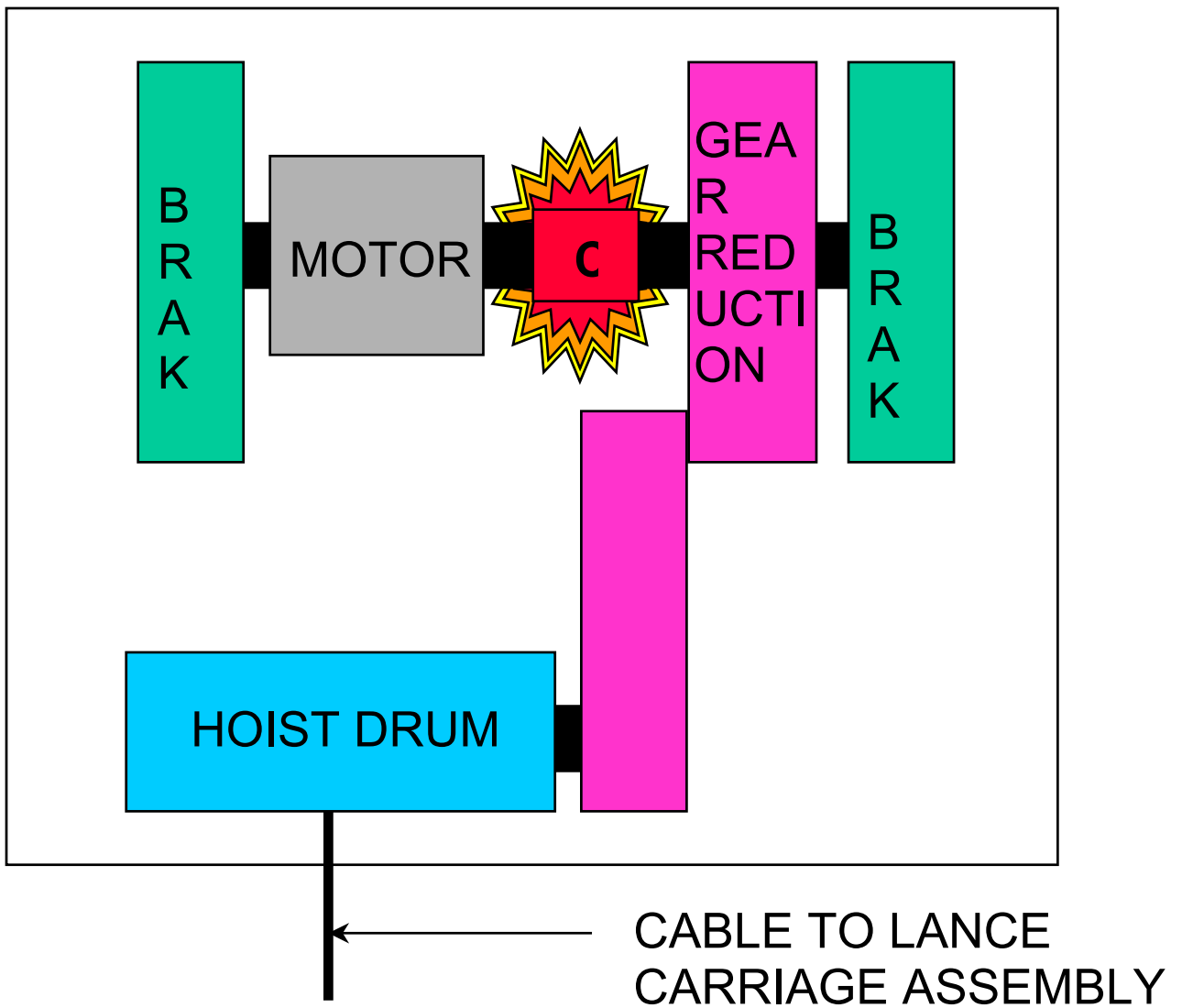

Figure 11.2: Hoist Drive Platform (Top View)

Sub-System	Event	Mode	Frequency	Impact/ Occurrence*	Total Annual Loss
#4 BOF	Catastrophic Failure of Lance Carriage Assembly	Lance Carriage Hits Floor	9/2 Years	\$257,940	~\$1,160,000

Table 11.1: Line Item from Modified FMEA

IDENTIFIED ROOT CAUSES:

Physical Roots -

- Excessive Vibration
- Insufficient Motor Movement Prevents Proper Alignment
- Improper Gear Mesh
- Wrong Hug Nut Installed on Brake Pull Rod
- Debris Under Sheave Plate Could Have Prevented Movement
- Dirt/Graphite Not Cleaned Out
- Current Design Allows Dirt to Accumulate

Human Roots -

- Unacceptable Conditions Not Observed During Field Inspections
- Severe Misalignment
- Field Inspection Error
- Aware of Unacceptable Conditions, But Not Responded To
- Current Safety Dog System Design Inadequate

Latent Roots -

- Torque Procedures for Coupling Bolts Non-Existent
- Inadequate Alignment Procedure
- Improper Alignment Tools Available
- Lack of Training in Proper Alignment Practices
- No Audit Function of Preventive Maintenance (PM) Inspections
- No Audit Procedure for PM Inspections
- Lack of Understanding Entire BOF Process/System
- PM Checklist Not On-Site
- Routine Inspections Not Assigned to Inspectors
- Inspections Seen as Undesirable Job
- Correct Hug Nuts Not Available in Stores
- Lack of Formal Training in Braking Systems
- New Brake Equipment Not Added to Inventory
- Safety Dogs Activated Too Late
- Coupling Failure Not Compensated For in Current Design
- Safety Dog System Designed Only to Activate During Slack Cable Condition
- Sheave Plate Area Perceived as Difficult/Unsafe Environment to Clean
- Multiple Levels/Floors to Clean
- Excessive Time and Effort to Set-up Vacuum Equipment
- Cleaning Perceived as Downturn Work
- Fewer Downturns Experienced Over Time
- PM Process Dictates Frequency of Inspections
- Perceived Lack of Time to Train in Overall BOF Process
- Job Conflict Perceived with PM Inspections
- Major Repairs to Other Equipment was of Higher Priority

- Maintenance Cleaning Tasks Perceived as Low Priority
- Mentality that Production is to be Maximized in the Short-Term
- Perception that there was not Enough Time to Align Properly

IMPLEMENTED CORRECTIVE ACTIONS:

- Precision Align All Components to Gear Reduction
- Re-Mesh All Gears
- Conduct Formal Training in Proper Alignment Practices
- Institute “Sign-Off” of Alignment on Drives
- Change Present Bases Out
- Survey Fabricated Bases Ensuring All Mounting Holes are Perpendicular and Parallel
- Modify Dry Gear Mesh to be Enclosed with Lubrication
- Change Gears in Sets
- Investigate “Unit” Exchange of Drive Assembly
- Conduct Formal Training on Brake Systems
- Update Computerized Maintenance Management System (CMMS) When New Equipment is Installed
- Inspect and Clean Safety Dog Gap on all Four Lane Carriages
- Improve Maintenance on Lance Carriages
- Incorporate Torque Specifications for Coupling Bolts in Alignment Sign-Off Document
- Include Torquing Effects in Formal Alignment Practices
- Rewrite Alignment Procedure to Include Special Requirements and Location of Alignment Tools and Brackets
- Utilize the Work Order System to Schedule Audits of PM Inspections to Include Standards of Inspection
- Conduct Brief Classes on the BOF Process and How the Equipment Functions Within that Process
- Provide a “Checklist” Carrier On-Site to Enable Timely Updating of the Inspections as they are being Performed
- Conduct Pre-Job Meetings in Which Possible Job Conflicts are Discussed and Resolved
- On Critical Jobs, Mandate that the PM Supervisor Audit Every Time
- Reduce or Eliminate the Fluctuation of PM Individuals Assigned to the Task
- Train the PM Supervisor to be Accountable for the Quality of the job Even if the Individuals are on the Job for the First Time (Again, Only on Critical Jobs Performed 100% by the PM Crews)
- Develop a New/Modified Equipment Checklist Which Ensures New Equipment and Spares are Added to the CMMS (RCM Tree) and Subsequently to the Inventory

- Replace the Overload/Underload Limit Switch System with a System Utilizing Load Cells
- Install New Boot System on Safety Dog Gap
- Perform Process Mapping Analysis
- Review Prioritization of FMEA/PMA Master Plans
- Distinguish Between Maintenance Cleaning and Housekeeping
- Challenge Perceptions of Downturn Needs
- Complete All Necessary Maintenance to Standards
- Investigate Paradigm of “Production is to be Maximized in the Short-Term”
- Conduct Sessions to Inform and Educate Everyone Involved who Must Support the Shift in Mind-Sets
- Hold Employees Accountable for Deviations in Product Continuity, Quality, Safety, etc. that are Manifestations of Behavior Stemming from the Old Paradigms
- Recognize those Employees Who Demonstrate with their Actions the Use of the New Paradigms

EFFECT ON BOTTOM-LINE:

TRACKING METRICS:

- PM’s Monitored Weekly
- PM Schedule Compliance Tracked Weekly
- PM Exceptions are Investigated and Countermeasures Taken
- Mean Time Between Failure (MTBF) and Mean Time To Restore (MTTR) are Tracked monthly

BOTTOM-LINE RESULTS

- MTBF Improved from 75 Days to 538 Days (and Counting). A 700% Increase
- Departmental PM Performance is Tops in the Plant
- \$1,150,000 Material Cost Reduction (1995 versus 1997)
- Experienced a Labor Reduction in Resources Necessary to Address Emergency Repairs. However, Utilized Additional Labor Resources to Increase PM Frequencies from Monthly to Weekly. This Basically Resulted in the Moving of Reactive Work to Proactive Work

CORRECTIVE ACTION TIME FRAMES

- Most Management System (Latent Roots) Were Addressed Immediately
- The Physical Redesign and Installation of the Upgraded Lance Carriage System Took Approximately 18 Months
- The Final Countermeasures of All Recommendations were Completed on June 30, 1998.

RCA TEAM STATISTICS

Start Date: November 16, 1996

End Date: June 26, 1997

Estimated Cost to Conduct RCA: \$30,000 **Estimated Returns from RCA:** \$1,150,000

Return on Investment: ~4000%

RCA TEAM ACKNOWLEDGEMENTS:

Principal Analyst: John Van Auken

Title: Day Supervisor-Maintenance

Company: ISPAT INLAND, INC.

Department: #4 BOF/#1 Slab Caster/RHOB

Site: East Chicago, IL

Core RCA Team Members:

Jeff Jones

Jim Modrowski

Mike Sliwa

Additional RCA Team Comments: The training and support from RCI during the RCA and their doggedness helped make this effort work. The real benefactors are ISPAT Inland, Inc. and their maintenance organization. We go about our business differently as a result of this RCA experience. It is not “assumed” that is the way it happened any more. We “deep drill” and come up with better countermeasures. #4 BOF is recognized as a leader in RCA and maintenance methodology at ISPAT Inland. Other departments are calling us for our ideas and advice. We are proud of this accomplishment. We cannot and will not rest on our laurels. There are other opportunities here and my hope is to see ISPAT Inland use this methodology even more and permanently eliminate more of our problems utilizing the 80/20 rule. RCI’s RCA methods are foolproof and proven. The proof is this RCA and its results.

JOHN VAN AUKEN
ISPAT INLAND
RCA PRINICIPAL ANALYST

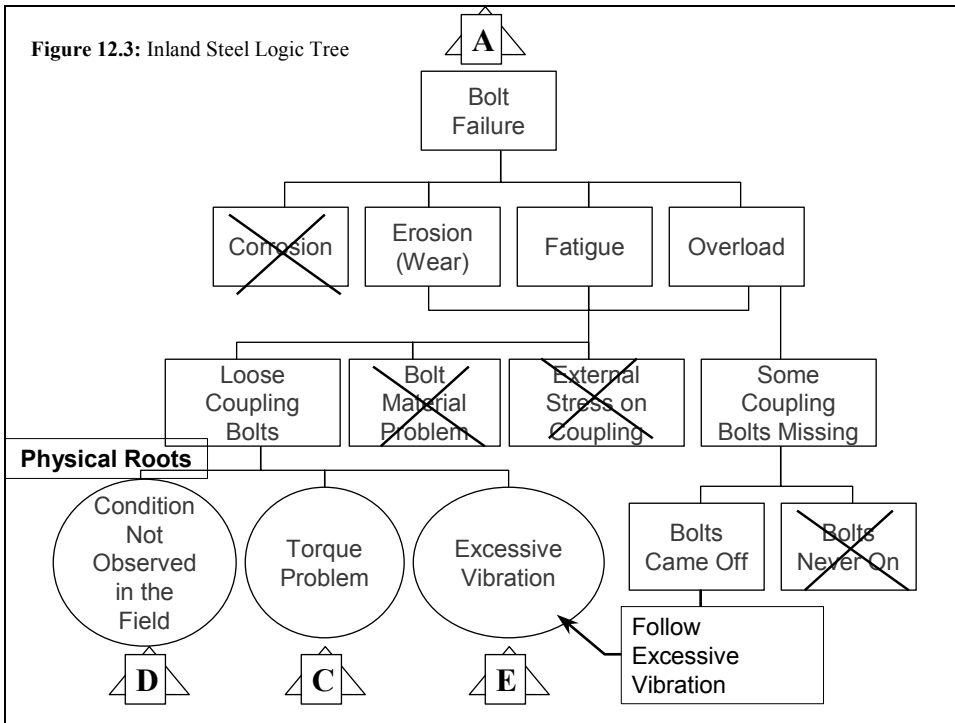
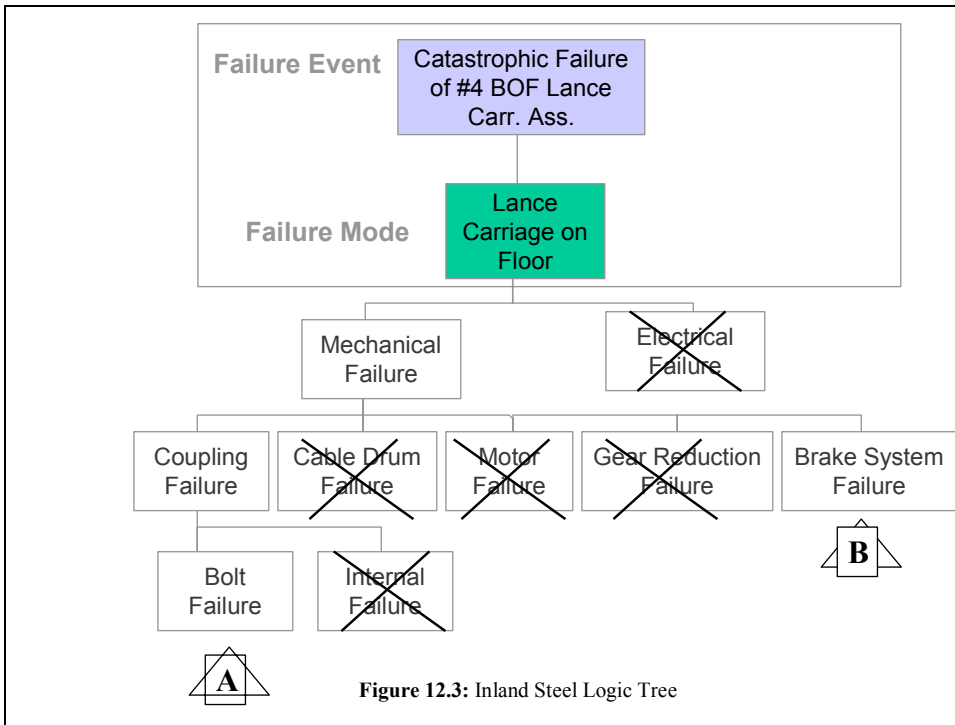

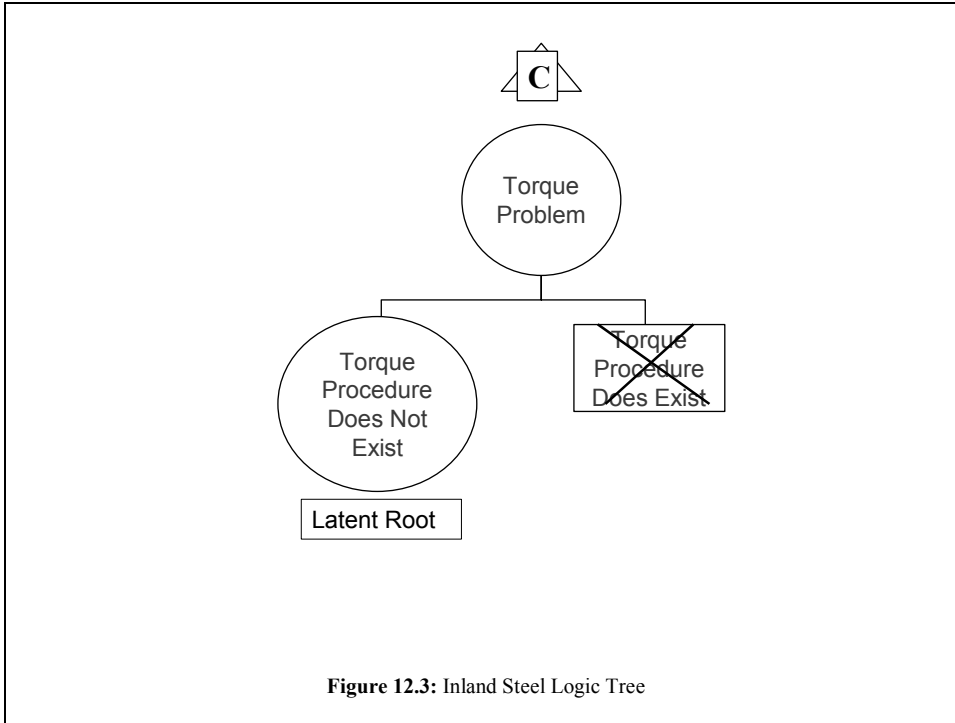

Figure 12.3: Inland Steel Logic Tree

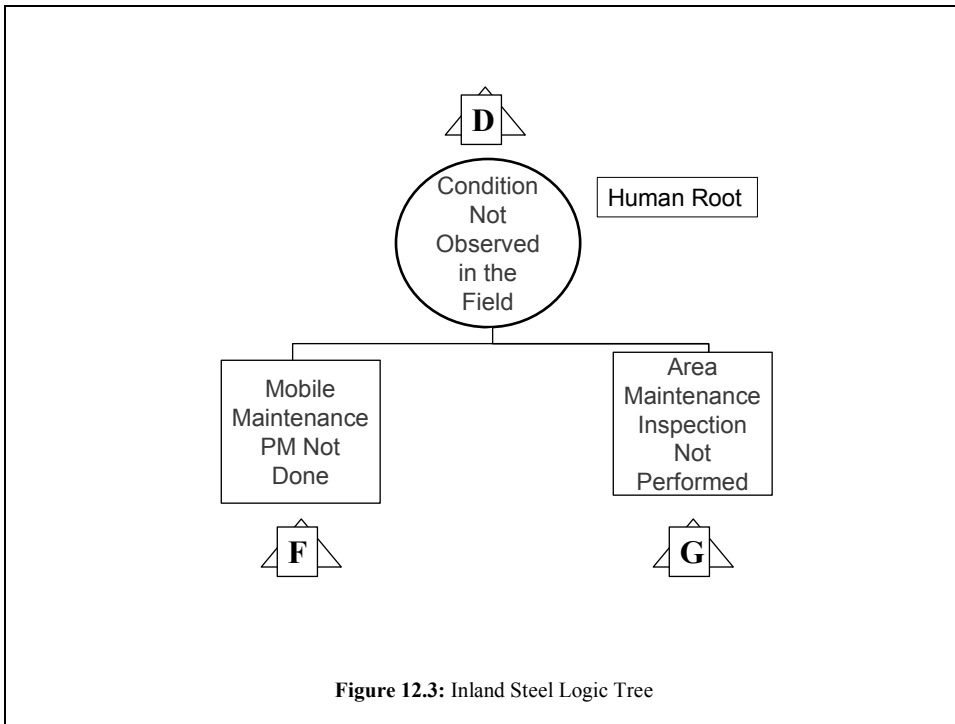
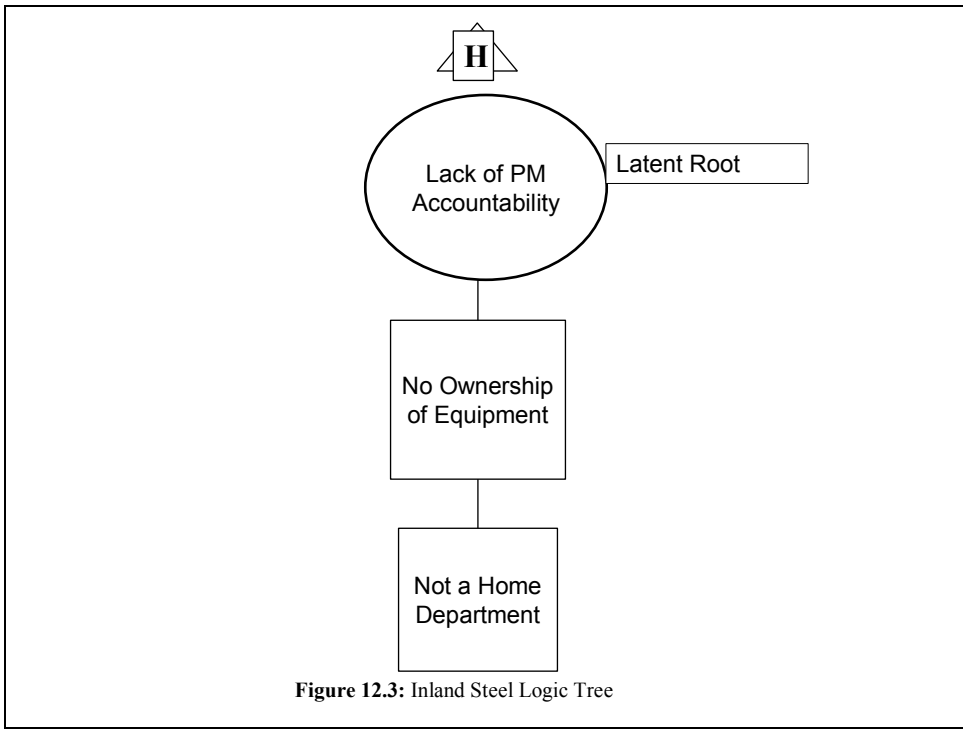
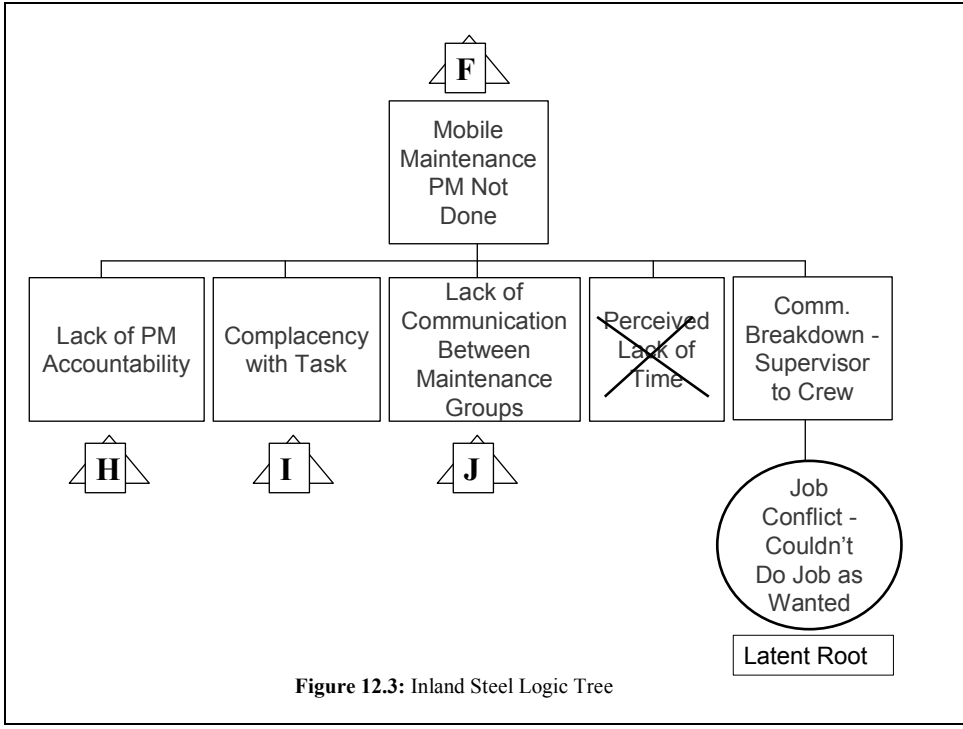

Figure 12.3: Inland Steel Logic Tree



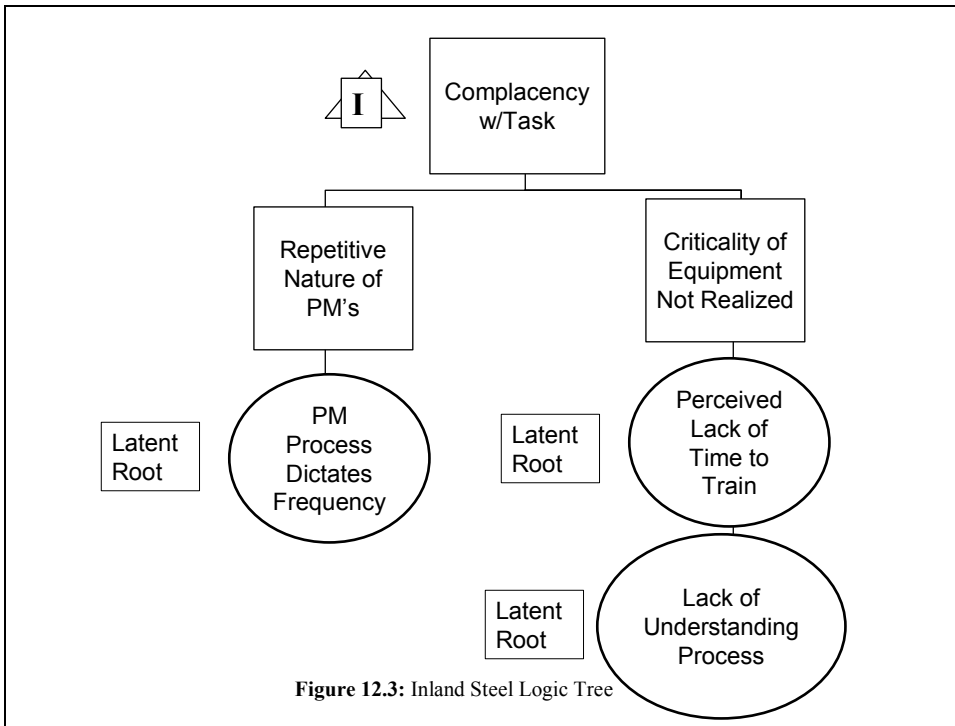

Figure 12.3: Inland Steel Logic Tree

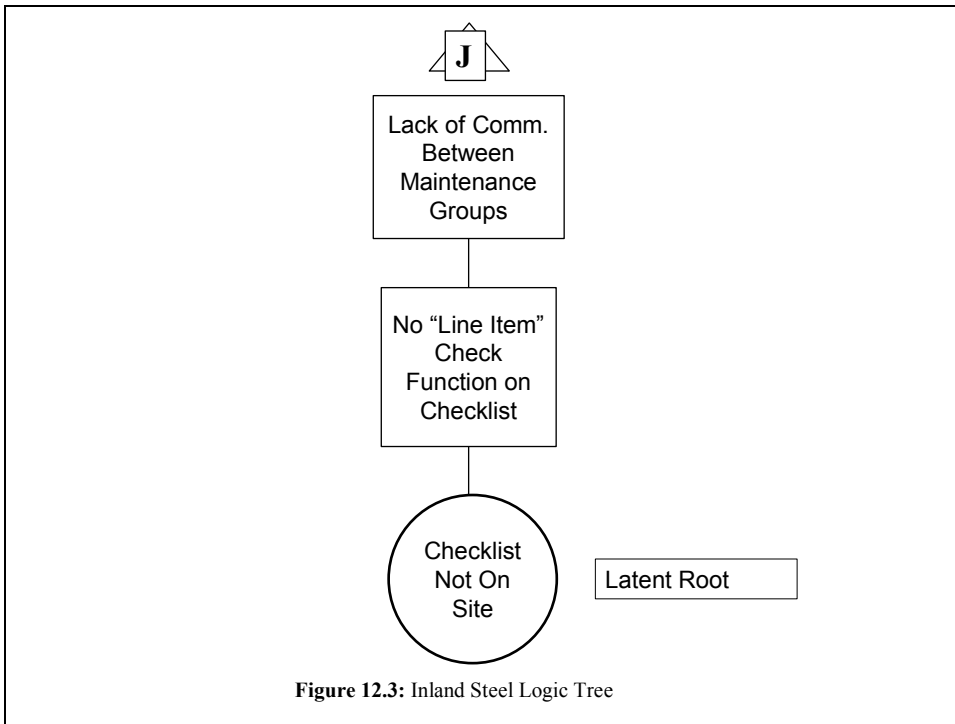

Figure 12.3: Inland Steel Logic Tree

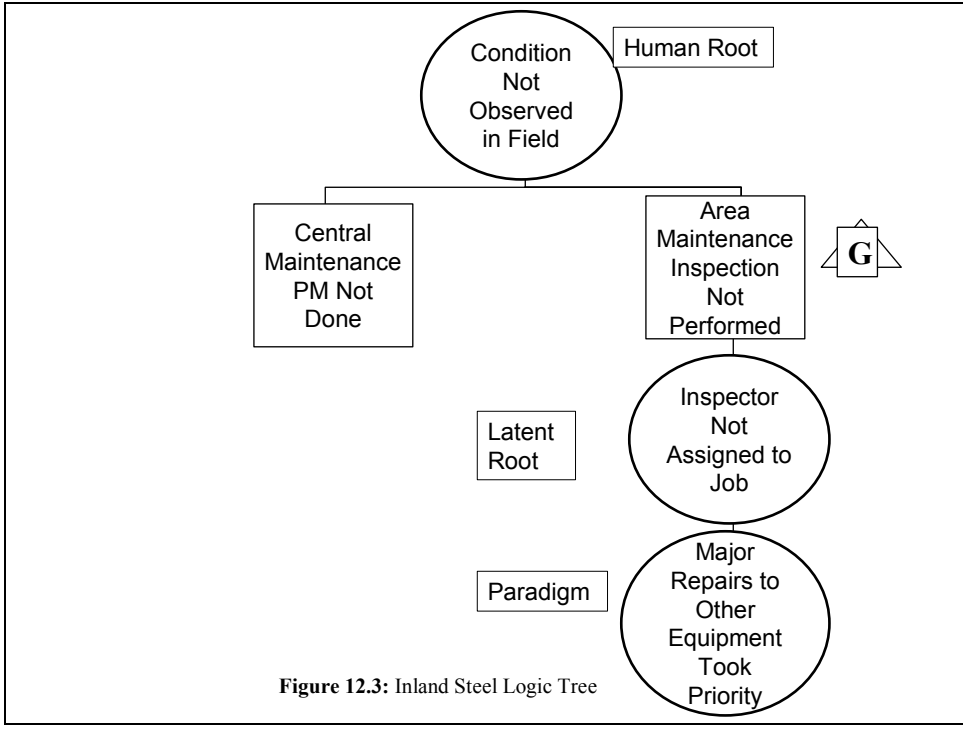

Figure 12.3: Inland Steel Logic Tree

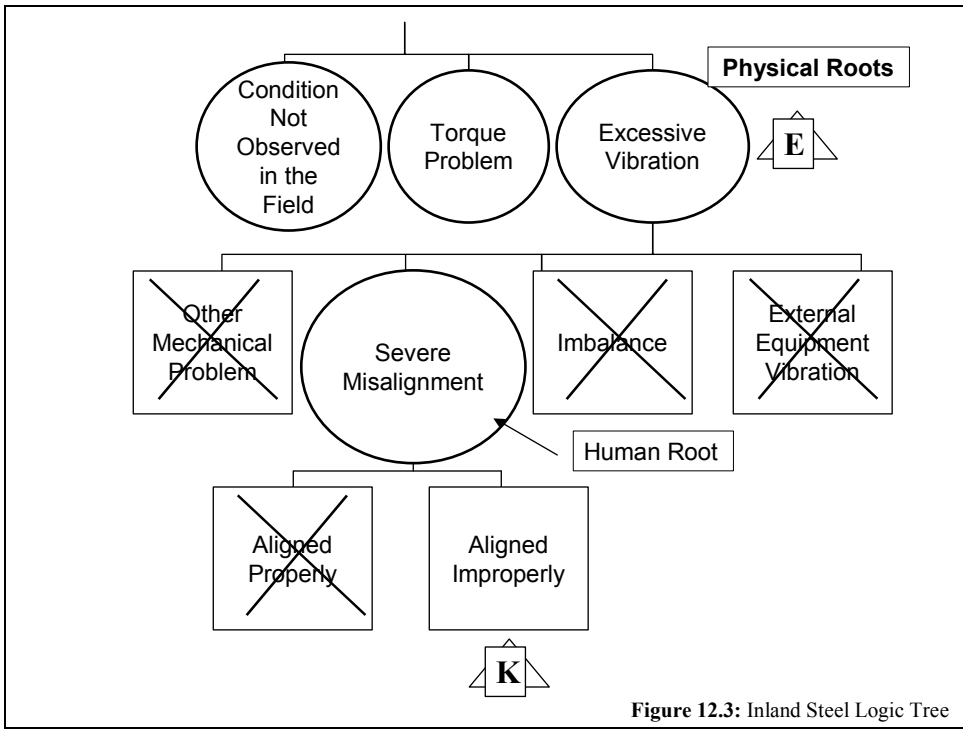
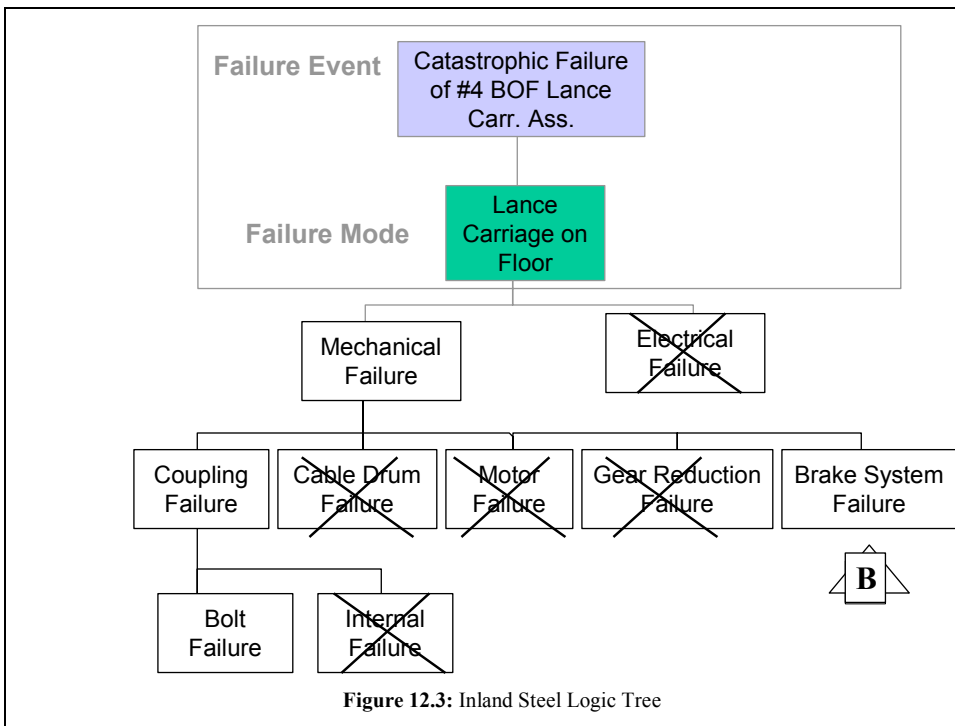
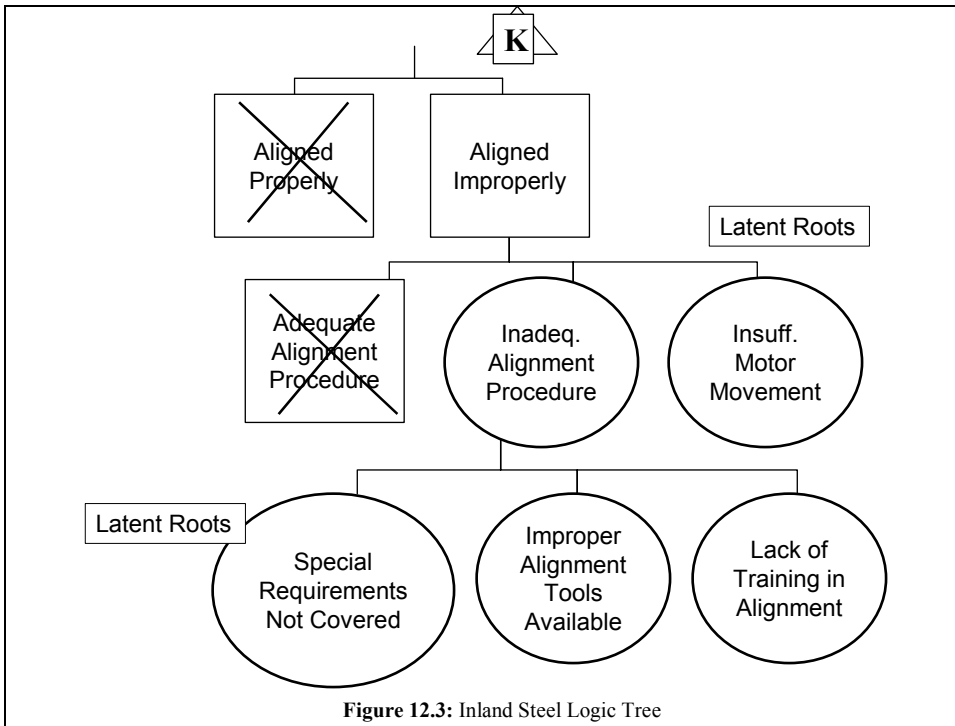

Figure 12.3: Inland Steel Logic Tree



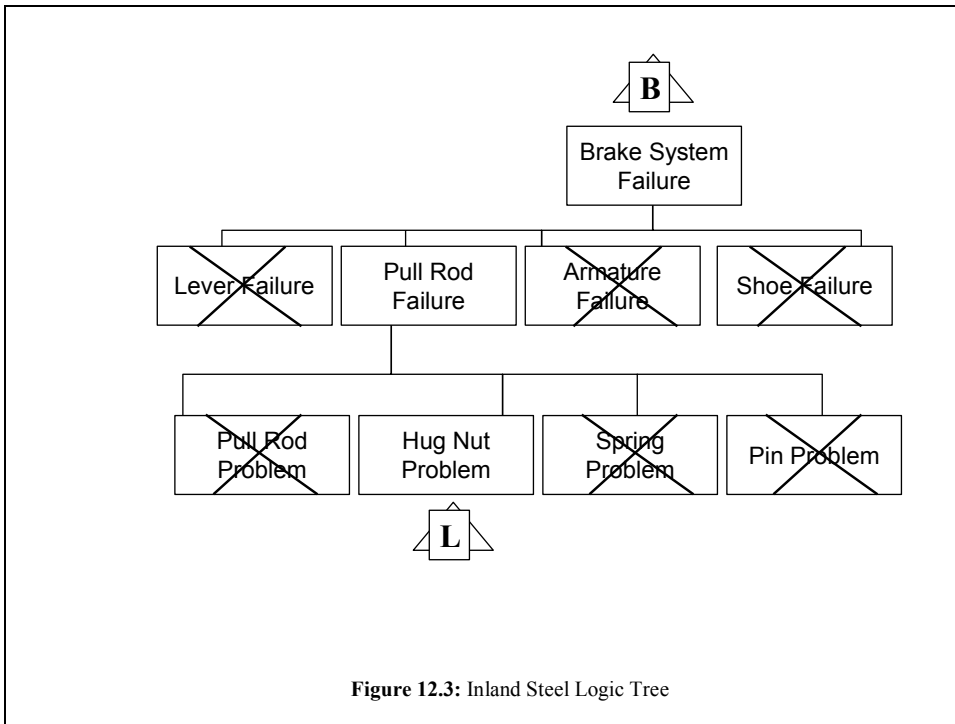

Figure 12.3: Inland Steel Logic Tree

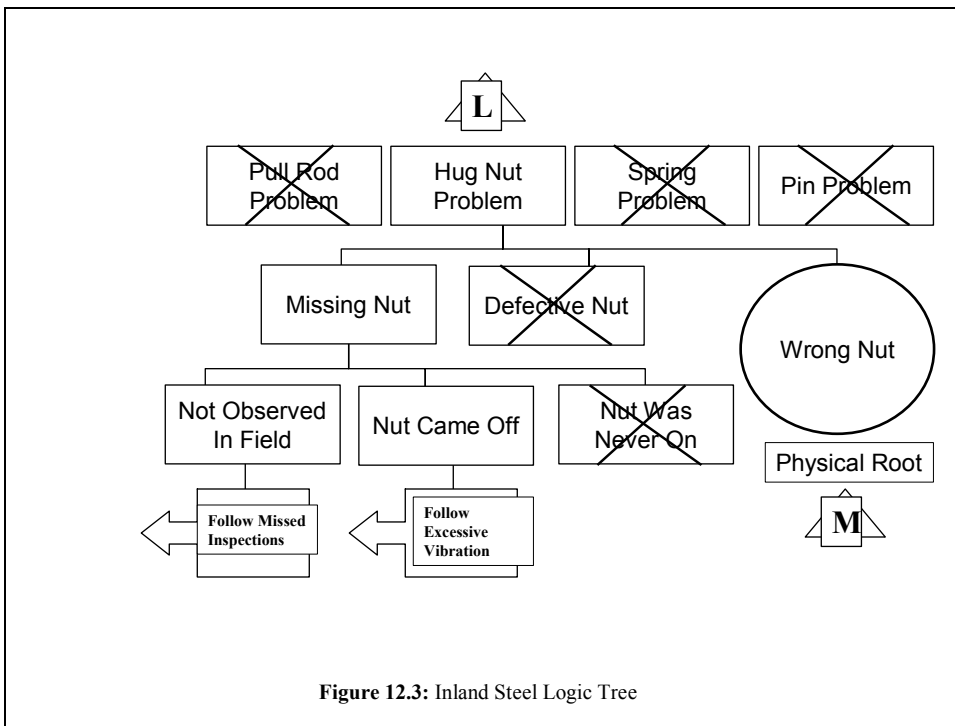

Figure 12.3: Inland Steel Logic Tree

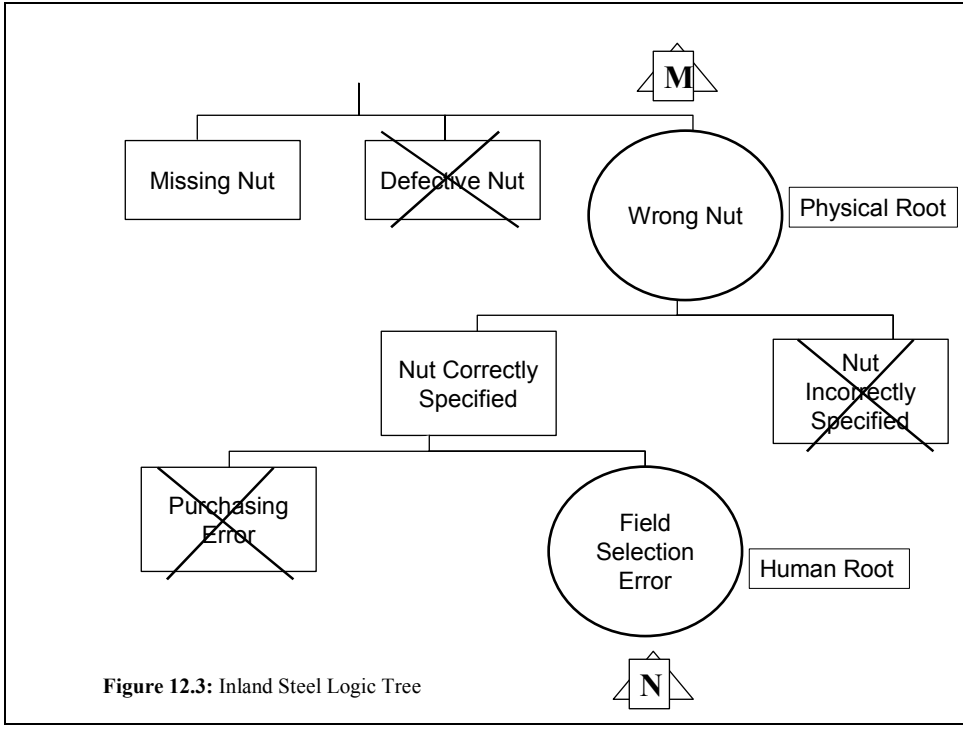

Figure 12.3: Inland Steel Logic Tree

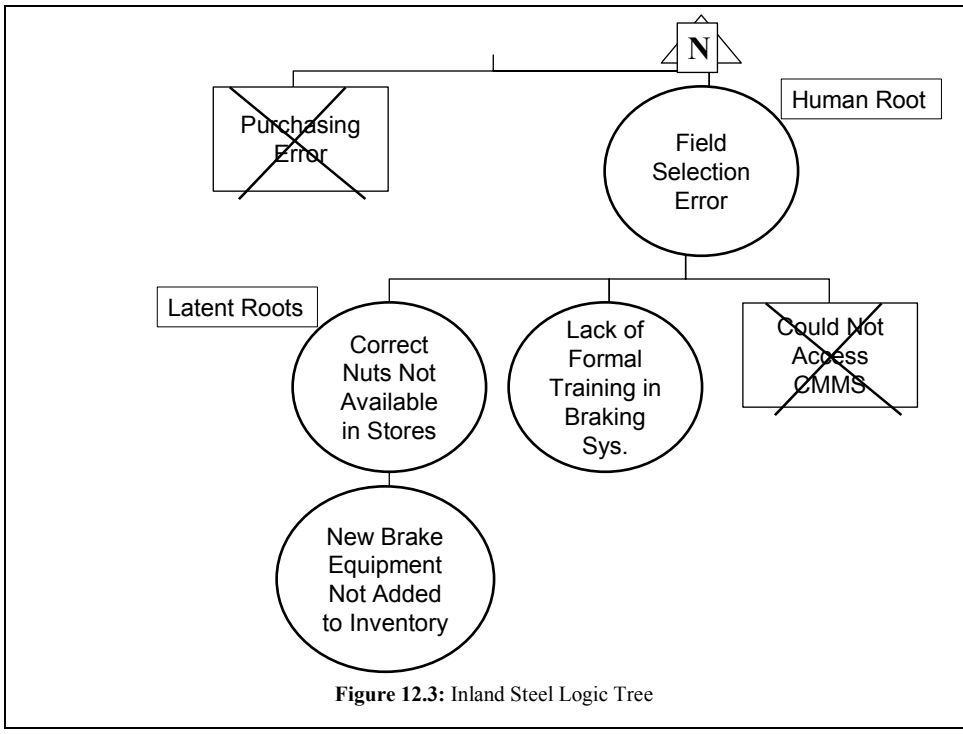

Figure 12.3: Inland Steel Logic Tree